

# PiConnect™ User Manual

Version: 05-2014

---

Closed Loop Grit Blasting





Any person intending to operate this equipment or any person intending to be in the vicinity during its operation must receive proper training.

Do not operate this equipment before reading and completely understanding all the warnings, cautions, operating procedures, and instructions contained in this manual. Do also read and understand the manual of the Pinovo® closed loop blasting and recycling unit PiSys™ and other relevant tools used with this equipment.



Registered design

## 1 INTRODUCTION

The PiConnect™ is a hand held closed loop grit blasting tool to be used with PiSys™ closed loop blasting and recycling unit. The tool is primarily intended for spot blasting and blast cleaning of small and medium sized metal structures. The surface is blast cleaned by using fused brown alumina as blasting medium. “White Metal” surface cleanliness according to SA 3 (ISO 8501-1) and SSPC-SP5 can be easily achieved in addition to an anchoring profile up to 120 µm. Furthermore, the Pinovo® closed loop grit blasting method inherently delivers feathered edges ideally suited to spot blasting and high quality coating repair.

Another advantage of Pinovo® grit blasting tools is the closed loop circulation system covering the entire treatment process. The result is complete elimination of discharges related to the work, as well as excellent utilization of the blasting medium. Brown fused aluminum oxide circulates in the system and may be re-used up to 25 times reducing media consumption and waste generation up to 90 % compared to conventional dry abrasive blasting technologies. In addition, the operators are never in direct contact with the actual blasting and waste material, which is collected automatically in the integrated waste management system.

No significant clean-up or further work is required after the Pinovo® preparation process, the surface is ready for painting or other post-treatment. The low noise and dust free Pinovo® surface preparation process minimizes the impact on surrounding trades and equipment.

The PiConnect™ has several different adapters, to be used on different types of geometries (see Chapter 4).

## 2 SAFETY INSTRUCTIONS

The products described in this manual are intended for knowledgeable, experienced users of abrasive blasting equipment. It is the responsibility of the user to ensure that proper training has been completed and to have the relevant certificates from the Pinovo training program.







It is the responsibility of the users to familiarize themselves with the appropriate laws, regulations and safe practices that apply to these products and materials that may be used with these products, and that a safe work environment is provided.





Any use outside the sphere of application specified by Pinovo is not approved. Such use, any failure to comply with the instructions given herein, or any modification of the product without the written consent of Pinovo will invalidate the warranty, and Pinovo refuses to accept liability.

In addition to information on installation and operation, this instruction manual may contain **WARNINGS** and **CAUTIONS** pertaining to user safety. A **WARNING** indicates a potentially hazardous situation, which if not avoided, could result in death or serious injury. A **CAUTION** indicates a potentially hazardous situation, which, if not avoided, may result in minor or major injury.











Do not attempt to operate this tool until you have read and understood all safety precautions and instructions listed in this manual. **INCORRECT OPEARATION OF THIS UNIT CAN CAUSE SERIOUS INJURY.**

### 2.1 Warnings

 <b>WARNING</b>	Enclosed blasting equipment may cause serious injury – protect hands, feet, eyes and hearing.
 <b>WARNING</b>	Show utmost care when connecting and operating the system. <b>ALWAYS THINK SAFETY FIRST!</b>
 <b>WARNING</b>	Wear PPE at all times when operating the PiConnect™. The type of respiratory protection should be considered depending on material being removed, e.g. lead-based coatings.
 <b>WARNING</b>	Do not use closed loop grit blasting tools on surfaces of unknown thickness or temperatures above 70°C without proper risk assessment.
 <b>WARNING</b>	Before starting the PiConnect™, ensure that all fixing screws, bolts and fittings are mounted correctly and securely tensioned. Also ensure that whip-checks and safety pins are used for all hose-connections and hook-ups.
 <b>WARNING</b>	Check all hoses for damage before starting the system.
 <b>WARNING</b>	Check for wear inside the PiConnect™ regularly. Change adapters regularly. Clean PiConnect™ from dust inside regularly.

 <b>WARNING</b>	Do not repair or replace any portion of Pinovo equipment using components that are not original Pinovo replacement parts or components that are not approved by Pinovo.
 <b>WARNING</b>	Do not cut, obstruct, restrict or pinch pneumatic control lines. Doing so could prevent the proper activation and deactivation of the remote control system, resulting in the release of high speed media and compressed air.
 <b>WARNING</b>	The use of this product for any purpose other than originally intended or altered from its original design is prohibited.
 <b>WARNING</b>	You must NEVER place your hand or fingers underneath the ‘Blast Head’ or point the ‘Blast Head’ of the PiConnect™ at yourself or anybody else while the system is pressurized.

## 2.2 Cautions

 <b>CAUTION</b>	Never install, remove or perform any maintenance on the PiConnect™ when the system is pressurized.
 <b>CAUTION</b>	Always use the dead man’s switch when operating the system. The dead man’s switch must never be set deliberately in an interlocked or blocked position, which could hamper the safety release of the switch.
 <b>CAUTION</b>	Only use Brown Fused Aluminum Oxide in the appropriate size, preferably sizes F12 to F46
 <b>CAUTION</b>	Blasting of oil contaminated parts may result in contaminated surfaces, clogged abrasive, and/or malfunctioning of the equipment.
 <b>CAUTION</b>	Valves must be opened slowly to allow seal to function correctly and to give a safe operation.
 <b>CAUTION</b>	Never operate the PiConnect™ while wearing loose hanging chains, hanging ID/Security badges or garments.
 <b>CAUTION</b>	Never start the PiConnect™ before its hoses are properly secured and safely located.
 <b>CAUTION</b>	The PiConnect™ should be properly maintained and stored when not in use to avoid damage to parts.
 <b>CAUTION</b>	Always consider the workplace, access and risk factor prior to installation.
 <b>CAUTION</b>	Always connect the hoses with safety line to fixed structure if working above 2 meters free fall.

## 3 OPERATING INSTRUCTIONS

The following illustration shows the different parts of the PiConnect™:

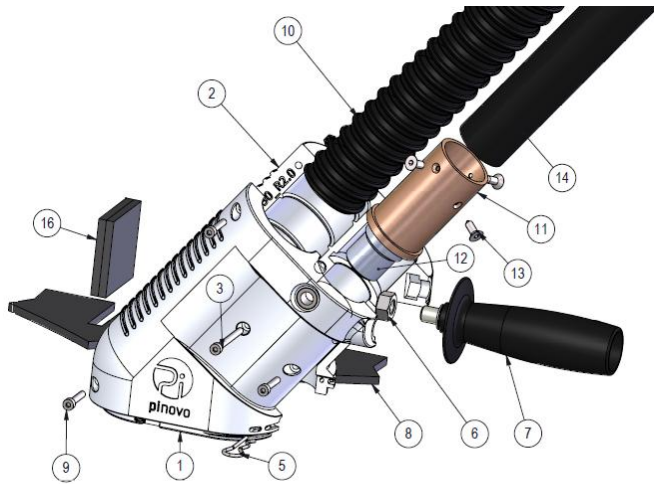

1. Housing left
2. Housing right
3. Screw M4x45
4. M4 nut
5. Locking pin
6. M10 nut
7. Removable handle
8. Rubber wear part
9. Screw M4x24
10. Antistatic vacuum hose 38 mm
11. Nozzle swivel
12. Nozzle (6.4 mm)
13. Screw 4.8 x 13 mm
14. Antistatic blast hose 3/4"
15. Product label
16. Rubber wall

- Before using the PiConnect™, perform a visual inspection, ensuring that all parts are in place and in good condition.
- Choose the correct adapter for the to be cleaned surface geometry. The different available adapters are explained in chapter 4.

**⚠ WARNING**

- Before fastening the adapter to the PiConnect™, ensure that either:
  - The system (PiSys™) is depressurised
  - The dead man twin hoses are disconnected
- Ensure that all hoses and connections are properly fastened.
- Make sure that all hoses are earthed all the way from the PiSys™ unit to the blast head.
- The adapter is fastened in the following steps:
  - Place the adapter at the front of the blasting area (flush to the opening of the housing)
  - Push the adapter forward so that it is fixed to the housing
  - Secure the adapter by placing the locking pin at the back of the housing/adapter
- Put the adapter wearing rubber in place, if necessary. It is very important that this is put in place properly, otherwise the grit will wear out the adapter and the housing very quickly. It is also important to change the wearing rubber in time.

- When starting to work with the PiConnect™, the ‘Blast head’ **MUST** be placed against the surface that is intended for blasting
- You must **NEVER** place your hand or fingers underneath the ‘Blast Head’ of the PiConnect™.
- You must **NEVER** point the ‘Blast Head’ of the PiConnect™ at yourself or anybody else.
- Only to be used with fused brown alumina grit (size F12 – F46).
- Recommended process parameters (PiSys™ 100):
  - Blast pressure: 3.5 – 4.5 bar
  - Suction pressure: 6 – 7 bar
  - Grit feed: 4 turns (New grit size F12: 4.5 turns)
- To achieve full abrasive and dust recovery the blast head must be in tight contact with the surface at all times. Do not apply excessive force that may cause the adapter brush to bend into the abrasive flow. Make straight, even passes. When reversing direction, move the blast head in a small radius to allow the bristles of the adapter brush to roll evenly and to prevent noise emission peaks.
- To start blast cleaning with the PiConnect™, activate the dead man’s handle.
- When stopping/pausing the blast operation, release the dead man’s handle. Wait until the system has come to a complete stop (no grit passing through) before lifting the blast head off the blast area.
- The PiConnect™ closed loop grit blasting tool in combination with the PiSys™ blast and recycling unit is approved for operation in potentially explosive atmospheres (ATEX zone 1 and zone 2).

## 4 ADAPTERS

- In case the adapter wear rubber is worn out, it should be replaced by the additional wear rubber supplied in the adapter package. Use of wear parts not supplied by Pinovo and/or other repair methods may compromise function and operational safety.
- In case the brushes and/or the main adapter part are worn-out or damaged, the adapter needs to be replaced with a new one.









**⚠ CAUTION**

- Using a worn-out adapter can cause dust leakage, high noise levels, and may result in damage to other parts or the surroundings.
- Use of wear parts not supplied by Pinovo and/or other repair methods may compromise function and operational safety.

**⚠ WARNING**

- Before changing the adapter, ensure that the system cannot be started, for example by either:
  - Depressurizing the system (PiSys™) or
  - Disconnecting the dead man twin hose
- The adapters can be released from the tool after removing the locking pin. The new adapter is fastened in the following steps:
  - Place the adapter at the front of the blasting area (flush to the opening of the housing)
  - Push the adapter forward so that it is fixed to the housing
  - Secure the adapter by placing the locking pin at the back of the housing/adapter

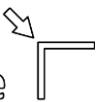
The following adapters are available for the PiConnect™ closed loop grit blasting tool

<p><b>11213 PiConnect™ Adapter Flat</b></p> <p>To be used on flat surfaces in combination with the PiConnect™ closed loop grit blasting tool.</p>	<p>Flat </p>	
<p><b>11217 PiConnect™ Adapter Flat XL</b></p> <p>To be used on flat surfaces in combination with the PiConnect™ closed loop grit blasting tool. It provides more stability than the PiConnect™ “FLAT” adapter, but has a larger footprint.</p>	<p>Flat </p>	
<p><b>11220 PiConnect™ Adapter Corner</b></p> <p>To be used on inside corners in combination with the PiConnect™ closed loop grit blasting tool.</p>	<p>Corner </p>	
<p><b>11223 PiConnect™ Adapter Edge</b></p> <p>To be used on outside corners (edges) in combination with the PiConnect™ closed loop grit blasting tool.</p>	<p>Edge </p>	

<p><b>11226 PiConnect™ Adapter 3" Pipe</b> To be used on 3 inch pipes in combination with the PiConnect™ closed loop grit blasting tool.</p>	<p>3" pipe </p>	
<p><b>11359 PiConnect™ Adapter 6" Pipe</b> To be used on 6 inch pipes in combination with the PiConnect™ closed loop grit blasting tool.</p>	<p>6" pipe </p>	
<p><b>11273 PiConnect™ Adapter 8" Pipe</b> To be used on 8 inch pipes in combination with the PiConnect™ closed loop grit blasting tool.</p>	<p>8" pipe </p>	
<p><b>11650 PiConnect™ Adapter 10" Pipe</b> To be used on 10 inch pipes in combination with the PiConnect™ closed loop grit blasting tool.</p>	<p>10" pipe </p>	
<p><b>11544 PiConnect™ Adapter Adjustable Edge</b> To be used on edges, especially on H- and T-beams, in combination with the PiConnect™ closed loop grit blasting tool. Adjustable for edges between 8 mm and 20 mm.</p>		
<p><b>11478 PiConnect™ Adapter Starter Kit</b> The starter kit comprises adapters for the most common geometries: 1 x Flat, 1 x Corner, 1 x Edge, 1 x 3" Pipe, 1 x 6" Pipe, 1 x 8" Pipe, and 1 x Adjustable Edge</p>		

In case you need adapters for additional surface geometries, please, contact your local Pinovo representative.

Adapters can be ordered by contacting your local Pinovo representative or directly via Pinovo's website: <http://www.pinovo.com/spares-requisition.html>

Please use the article number provided in this manual for your orders.

## 5 EXCHANGE OF WEAR PARTS

- The 38 mm suction hose connected to the PiConnect™ housing is to be checked prior to every start-up, and needs to be replaced when worn out.



- To exchange the 38 mm suction hose, you have to disassemble and open the PiConnect™ housing. To do so the M4-screws (see Chapter 3 – Nos 3 and 9) have to be removed, the suction hose has to be replaced, and the housing has to be closed again by fastening the M4-screws. Check that the suction hose is securely fastened and cannot be removed from the closed housing.

**Only use original replacement hoses supplied by Pinovo.**

#### **11659 PiConnect™ Suction Hose**

Flexible, abrasion-proof and electrically conductive rubber suction hose.

Diameter: 38 mm – Length: 6 m – Male 2” Camlock coupling

Wear parts can be ordered by contacting your local Pinovo representative or directly via Pinovo’s website: <http://www.pinovo.com/spares-requisition.html>

Please use article number provided in this manual for your orders.

The wear rubber inside the PiConnect™ housing (see Chapter 3 – No 8) and the rubber wall separating the blast and suction areas inside the housing (see Chapter 3 – No 16) need to be inspected frequently, at least every working shift. In case the rubber thickness is less than 1.5 mm, Pinovo services should be contacted for replacement.

## **6 ACCESSORIES**

The following accessory is available for working with the PiConnect™.

#### **PiStick Ergonomic Support Tool**

PiStick™ is an ergonomic support tool for work with the PiConnect™ closed loop grit blasting tool.

The set contains a length adjustable aluminum pole (1), a fixture for the PiConnect™ closed loop grit blasting tool with adjustable angle (2), attachment bolts (3), and a support belt to hold the aluminum pole (4a) with laces for attaching the hoses (4b).

PiStick™ can be used to ease closed loop grit blasting of walls, ceilings, and/or floors

For more information, please, contact your local Pinovo representative



## 7 TECHNICAL DATA

Size L x W x H (mm), excluding hoses and adapter	124 x 176 x 62
Weight (kg), excluding hoses and adapter	1.0
Nozzle Type	6.4 mm Venturi nozzle
ATEX conformity	CE  II 2G IIA T4

---

### Main Office

**Visit:** Sanddalsringen 3, NO-5225 Nesttun

**Postal:** PO Box 154, NO-5828 Bergen

**Country:** Norway

**Phone:** +47 907 55 500

[www.pinovo.com](http://www.pinovo.com)

### Pinovo UK

**Visit/Postal:** C/O AquaTerra Group,  
AquaTerra House, Tofthills Ave., Midmill  
Business Park, Kintore, Aberdeen, AB51 0QP

**Country:** Scotland

**Phone:** +44 7551 891 818